



The Global Leader in High Power Ultrasonics



RITEC RPR-4000

High Power Tone Burst Pulser and Receiver:

- High Power RF Tone Burst Pulses up to 8 kilowatts for frequencies up to 2 MHz.
- Two Standard Frequency Ranges covering frequencies from 50 kHz to 20 MHz.
- Custom Frequency Ranges also available.
- Front panel control with keypad and display
- Robust environmentally tolerant packaging

RITEC, Inc. • 60 Alhambra Rd., Suite 5 • Warwick, RI 02886
(401) 738-3660 • FAX (401) 738-3661

www.RitecInc.com

Powerful Ultrasonic Pulser/Receiver

The RITEC RPR-4000 is a high power ultrasonic measurement system designed for the nondestructive evaluation of materials properties. Some special capabilities not available in other commercial instruments include:

- The ability to make reproducible measurements using short (down to single cycle) radio frequency (RF) tone burst excitations in composites and other difficult materials,
- High power RF tone burst excitations up to 8 kilowatts, providing ability to drive inefficient transducers, such as electromagnetic acoustic transducers (EMATs) or high capacity, low frequency piezoelectric transducers, at a maximum duty cycle of 1%.
- This remarkable instrument has been designed to withstand severe environmental pollution and high temperatures while providing the most powerful tone burst available to the ultrasonic testing market.

Environmentally Tolerant Packaging

The internal volume of the RPR-4000 has been designed to divide the available space into two sections; one for critical electronics and one for cooling air flow across heat radiators. Outside air brought into the cabinet to circulate over the heat radiators is exhausted out the rear panel and is not exposed to any of the electronics. This means that the RPR-4000 is ideally suited for harsh industrial environments. High efficiency zero-voltage-crossing switching power supplies are used for all DC voltage requirements. All power supplies are fully shielded.

The RPR-4000 has been tested at full duty cycle in environments up to 100 degrees Fahrenheit

(38 degrees Celsius). If an over temperature condition should develop, an automatic shutdown feature will be enabled.

A Modular Approach

The instrumentation for this sophisticated, complete ultrasonic system has been divided into five functional modules. Each module performs a specific task and can be tested, and modified individually. The critical modules, namely the power supply, the low level and high level stages of the pulser, and the receiver are enclosed in individual shielded cases so that switching noise from the supplies is not introduced into the pulser or receiver.

The RPR-4000 pulser/receiver consists of the following elements:

- I. A broadband, high power gated amplifier for producing RF bursts, derived from a gated direct-digital RF synthesizer, to drive various types of transducers, including piezoelectric, air-coupled and electromagnetic acoustic transducers (EMATs).
- II. Timing to produce the gates required to turn the amplifier on and off coherently with the output from the direct-digital synthesizer. A microprocessor on the timing also controls the gating for the synthesizer, the frequency of the synthesizer output and the gain controls for the gated amplifier output.
- III. A low noise broadband receiver to amplify ultrasonic signals either from the transmitting transducer, using the internal diplexer, or from a separate receiving transducer. A microprocessor in the receiver controls the receiver gain, filter settings and receiver input.
- IV. A front panel console with a LCD display and keypad. The console unit also has a microprocessor to control the display and

RITEC, Inc. • 60 Alhambra Rd., Suite 5 • Warwick, RI 02886

(401) 738-3660 • FAX (401) 738-3661

www.RitecInc.com

the serial interface (RS-232) to the external computer.

- V. An internal diplexer (transmit/receive switch) for operation in pulse/echo mode with a single transducer.

The front panel keypad and menu screens provide control of all functions including tone burst frequency, width, repetition rate, receiver gain, input selector and filter selection. Up to 10 sets of operating parameters can be saved for future recall. The RPR-4000 can be controlled from an external computer via the RS-232 serial interface.

A block diagram of the RPR-4000 system is shown in Figure 1.

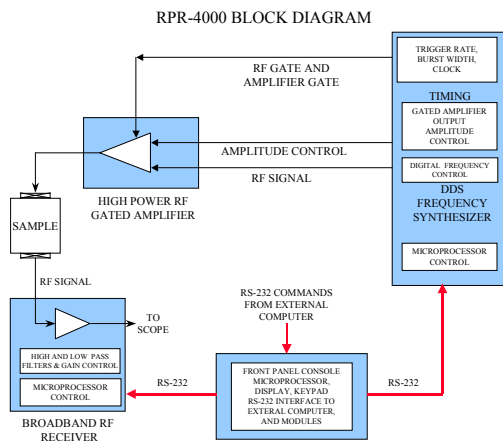

Figure 1

Block Diagram of the RPR-4000 High Power Pulser/Receiver System

Each of the various system functions will be briefly described below.

High Power Gated RF Amplifier

Current applications for industrial testing, evaluation and modern research studies require very high power RF tone bursts to drive the transducer. The RITEC gated RF amplifier is designed to derive these high power pulses from a radio frequency source, with the addition

of timing gates produced externally and/or from the timing module. These RF bursts may then be used to drive various types of ultrasonic transducers, such as piezoelectrics or EMATs. When highly attenuative materials are encountered, long bursts containing numerous cycles may be used to generate very large sound amplitudes. These long tone bursts can also be used to drive the sample into acoustic resonance, which allows the use of inefficient transducers and improves the signal to noise. A block diagram of the gated amplifier is shown in Figure 2.

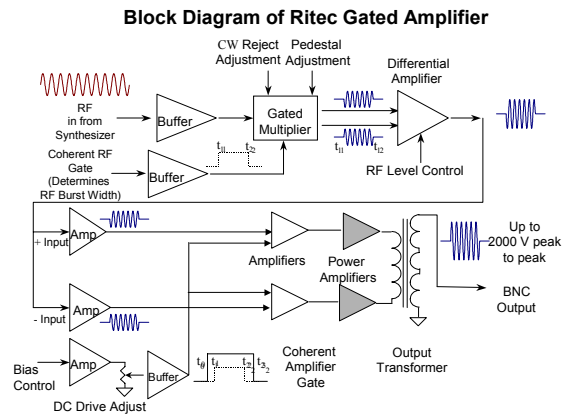

Figure 2

A Block Diagram of the RPR-4000 Gated Amplifier

The high power RF burst is created by selecting a number of RF cycles (times t_1 to t_2) from a synthesizer running in a gated mode. This is accomplished by turning on the amplifier with a gate that is coherent with the synthesizer output. The low level signal is then sent to a variable gain amplifier whose output is then split into two signals 180 degrees apart to drive two final amplifier stages. The high power outputs from these final amplifier stages are combined in an output transformer to produce the high power bipolar RF burst. This configuration is known as a "push-pull" configuration. Depending on the transistors used in the final amplifier stages and the frequency range and bandwidth of the output power transformer, the gated amplifier

can be customized for specific ranges of frequency.

When the greatest time resolution is required, the unique gating circuitry allows the gated amplifier to produce a clean single cycle of RF up to 5 MHz. Single cycle RF bursts give comparable resolution to spike pulsers in many situations. The unique gating turns on the final output stages at times (t_0 and t_3) before and after the low level tone burst. Typically, the gated amplifier output stage is turned on 1 microsecond before the tone burst and turned off 50 nanoseconds after the tone burst. A typical burst, into a high power 50 Ohm load, is shown in Figure 3.

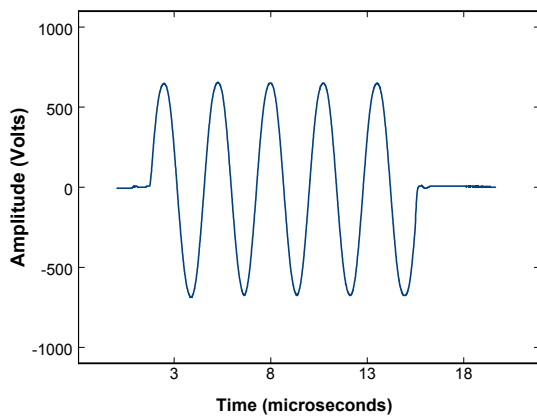

Figure 3

A high power RF burst of five cycles at 350 kHz

The high power gated amplifier has a maximum available output pulse power of 900 V peak (1800 V peak-to-peak) or 8 kilowatts (kW) root-mean-squared (RMS) into a 50 Ohm load. At some frequencies, the maximum saturated pulse power can approach 1000 V peak or 10 kW RMS. (At the saturated power levels, the sine wave output amplitude will be limited and will approach a square wave output, with appreciable harmonic content.) The high powers and voltages available must be considered when selecting piezoelectric transducers.

Please note that these power measurements are RMS measurements; peak pulse power measurements would be double of those RMS power measurements (16 kW peak). Some other amplifier manufacturers quote peak pulse powers. The front panel display shows approximate peak positive output voltage of the gated amplifier; the output voltage will depend on the impedance of the transducer.

With the high frequency version, the frequency range where the 8 kW power is available is restricted to 1 decade of frequency up to a maximum frequency of 2 MHz. Typical ranges are 50 kHz to 3 MHz, and 250 kHz to 7 MHz. A plot of the available voltages as a function of frequency for the high frequency version of the amplifier is shown in Figure 4. The upper trace is for the saturated RF power output from the RPR-4000; the bottom trace is for the maximum sinusoidal RF power output.

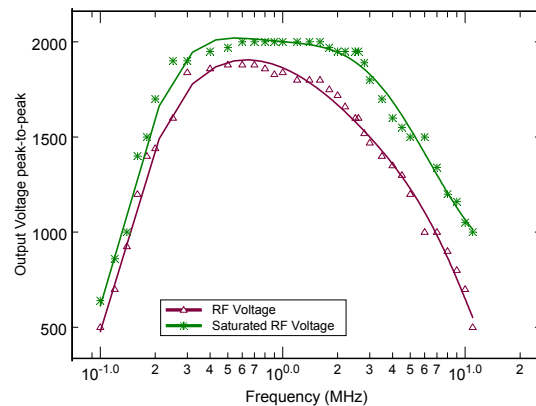

Figure 4

Maximum available power for the high frequency version of the RPR-4000

The noise level of the gated amplifier during the receive time is also very low because the amplifier has been turned off. The ratio of the pulse amplitude to the RF leakage through the amplifier (On-Off ratio) is greater than 140 dB. This high On-Off ratio is important because a very small amount of leakage can overwhelm the receiver input at high gains.

This reduction in leakage of the RF signal is a major advantage of using an amplifier that is gated as opposed to an amplifier that operates continuously amplifying externally produced low-level RF bursts. Another advantage is that the amplifier has been turned off and is no longer amplifying any noise that may be present on the low level RF input, thus improving the signal-to-noise. Other advantages are the economies realized in size, heat dissipation, and power supply requirements.

Because the amplifier is gated on and off, an important factor to consider when determining the burst width and burst repetition rate or trigger frequency is the duty cycle. This is defined as the time the amplifier is turned on, specifically the burst width multiplied by the repetition rate, expressed as a percentage. For example, as shown above in Figure 3, at an operating frequency of 350 kHz a burst width of five cycles results in a burst 14 microseconds long. At a repetition rate of 100 Hz, the duty cycle would be 0.0014 or 0.14%. At a repetition rate of 1kHz, the duty cycle would be 1.4%. As this exceeds the maximum duty cycle limit of 1%, the control microprocessor will automatically reduce the burst width to 3 cycles as the repetition rate is increased to 1 kHz.

No appreciable sag in output amplitude will occur as the duty cycle limits are approached at full power. If the 1% duty cycle limit is exceeded, the microprocessor on the timing and gated amplifier control board will automatically limit the burst width. If the output voltage limit of 1100V peak is exceeded, the microprocessor will automatically turn down the output controls and sound an audible alarm. (Full power output can be restored by turning down the output control.) If the over current limit is exceeded, or if the over temperature limit of 75 degrees Celsius is exceeded, the microprocessor will turn off the high voltage supply and sound the alarm.

The high power available makes it possible to drive very low efficiency transducers such as EMATs and still have reasonable system

performance. In addition, when materials exhibiting high ultrasonic losses are to be examined, the use of high power in conjunction with efficient transducers can mean the difference between meaningful data and no observable signals.

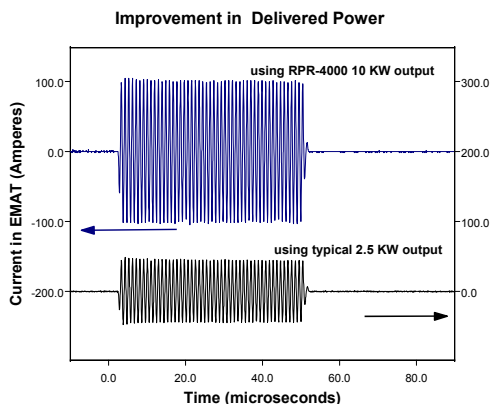

Figure 5

Available current in an EMAT with the 10 kW output burst from the RPR-4000.

An example of the improvement in delivered power or, in the case of EMATS, in the delivered current is shown in Figure 5. With EMATs, the ultrasonic signal generated in the sample is directly related to the currents generated in the EMAT. The RPR-4000 can deliver peak RF currents approaching 100 amperes at maximum power of 10 kW versus other available 2.5 kW tone burst amplifiers, which can deliver 50 peak amperes. The improvement in delivered power results in a 6 dB increase in the signal to noise ratio of the received signals.

Frequency Synthesizer

The frequency source is provided through a direct digital synthesizer that produces instantaneous changes in frequency as contrasted to the settling times required in phase locked looped synthesizers. The synthesizer produces tone burst signals at frequencies up to 20 MHz. The synthesizer accepts an external clock signal at frequencies up to 20 MHz, internally multiplying the clock to 140 MHz. Frequency control is provided with a

RITEC, Inc. • 60 Alhambra Rd., Suite 5 • Warwick, RI 02886

(401) 738-3660 • FAX (401) 738-3661

www.RitecInc.com

programming resolution of 1 Hz. The synthesizer output is sent to the gated amplifier for additional gating and amplification. An external RF input is provided on the rear panel of the RPR-4000 in cases where an external waveform generator or arbitrary waveform generator is used.

Timing

All the digital timing functions of the RPR-4000 are coherent to the 20 MHz synthesizer clock, which is available on the rear panel of the instrument. The timing functions under control by the front panel display are the repetition rate, the trigger source and the tone burst width. The tone burst width can be controlled either in the number of RF cycles or in microseconds. The trigger source can be selected between the internal repetition rate generator, the external trigger input or a software trigger, sent by the external computer.

When a trigger is received, the timing circuitry starts the amplifier gate for the output stage of the gated amplifier. After 1 microsecond, it starts the synthesizer output at a positive zero crossing of the RF signal. The timing circuitry then controls the synthesizer output to produce a tone burst of the desired width. At the same time the tone burst begins, a trigger pulse is sent to the trigger output connector. After the tone burst is stopped, the amplifier gate is turned off. This amplifier gate is available as a TTL/CMOS level monitor on the rear panel of the instrument. If an external waveform generator is used, an external gate from the generator may be input through a rear panel connector.

Broadband Receiver

The low noise broadband receiver has a gain control range of 20 to 100 dB in 0.4 dB steps. One of the two front panel inputs may be selected for amplification in the receiver, either on a continuous basis during setup or on a time-shared basis, on every alternate trigger. The

noise figure is approximately 6 dB at 100 dB of gain. The bandwidth of the receiver is matched to the frequency range of the gated amplifier; the maximum bandwidth for the receiver circuitry is 50 kHz to 20 MHz. For the 50 kHz instrument, the bandwidth of the receiver is 50 kHz to 3.2 MHz; for the 250 kHz instrument, the bandwidth of the receiver is 200 kHz to 20 MHz. Custom frequency ranges can be specified. By adjusting the high pass and low pass filter settings, the bandwidth may be reduced, increasing the signal-to-noise-ratio of the received signal. The maximum linear output of 1 volt peak-to-peak makes the receiver an ideal device interface with a digitizing oscilloscope card to capture the received waveform.

Low Insertion Broadband Diplexer

Most diplexer or transmit/receive switches, used for pulse/echo operation with a single transducer, are used at specific operating frequencies or have a large insertion loss in the signal transferred to the receiver. The RPR-4000 contains a unique low insertion loss (approximately 3 dB) diplexer for operation with a single transducer. The diplexer output to the receiver is brought out to the front panel for easy access.

Packaging

The RPR-4000 cabinet can be rack mounted in a standard 19-inch rack. The cabinet is 4 U high and 17 inches deep. The internal volume of the RPR-4000 is divided into two sections; one for critical electronics and one for cooling air flow across heat radiators. Outside air brought into the cabinet through the bottom cover, is circulated over the heat radiators for the gated amplifiers and the power supply by five fans. The air is then exhausted out the rear panel, through two fans on the rear panel and is not exposed to any of the electronics. This means that the RPR-4000 is ideally suited for harsh industrial environments, especially in the presence of conducting particulates, such as carbon or fine steel dust. The air path is shown

RITEC, Inc. • 60 Alhambra Rd., Suite 5 • Warwick, RI 02886

(401) 738-3660 • FAX (401) 738-3661

www.RitecInc.com

in Figure 6 below.

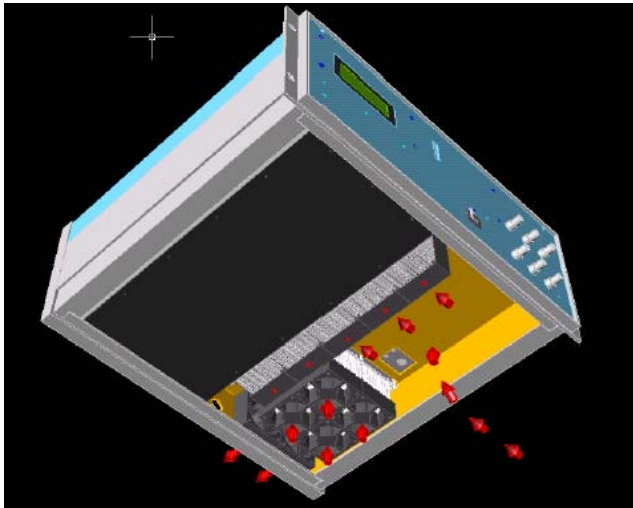

Figure 6

Airflow across the heat radiators inside the RPR-4000

All the high power electronics is enclosed in shielded modules along with the low-noise receiver electronics.



Figure 7

Front Panel Display and Keypad

The front panel overlay, which contains the touch keypad and the window for the console display, is made from a durable plastic and can be easily cleaned. The 4-line display is backlit and is an easily readable white on blue LCD display.

Evaluation Tests

Several evaluation tests were made using the RPR-4000 to demonstrate the performance of the instrument. The first tests used the RPR-4000 to drive a 910 kHz meander line EMAT, generating a longitudinal ultrasonic wave, on a 12-inch segment of a train rail. The first test was made transmitting in pulse/echo mode, using the internal diplexer, from the top of the rail. The results with two different power levels are shown below in Figures 8 and 9. The upper trace was made using the RPR-4000 at the maximum output power of 10 kW. The receiver gain was set to 70 dB. The lower trace was made using a 2.5 kW tone burst pulse to drive the EMAT. The peak currents in this particular EMAT were shown earlier in Figure 5.

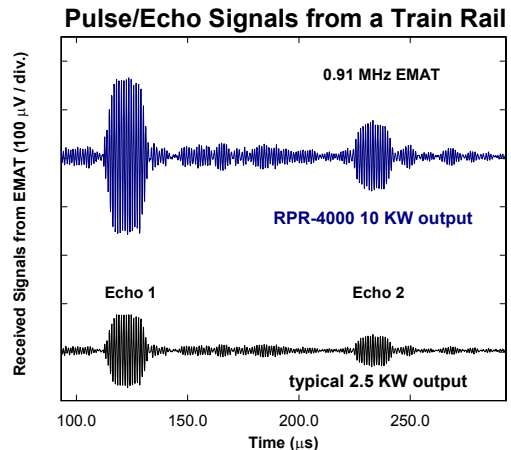

Figure 8

Received Signals transmitting from the top of the rail track

RITEC, Inc. • 60 Alhambra Rd., Suite 5 • Warwick, RI 02886

(401) 738-3660 • FAX (401) 738-3661

www.RitecInc.com

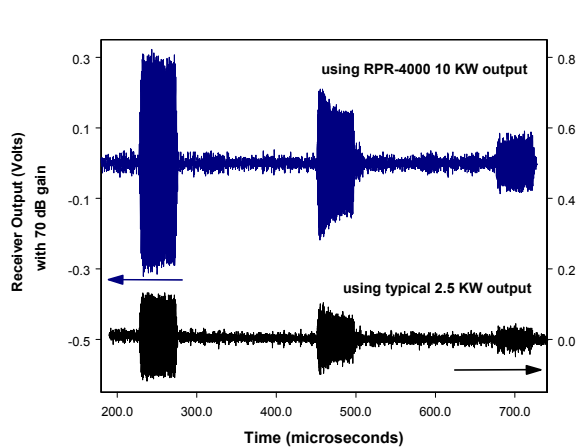

Figure 9

*Received Signals transmitting
Down the axis of the rail track*

The increased power available from the RPR-4000, in addition to improving the amplitude of the ultrasonic signal, also results in an improvement in the signal-to-noise over other pulsers. In the data shown below in Figure 10, one of the later round-trip echoes was selected and amplified for a peak-to-peak output of 100 millivolts. The same process was done with the 2.5 kW pulser/receiver. The improvement of 6 dB in the signal-to-noise ratio can be clearly observed.

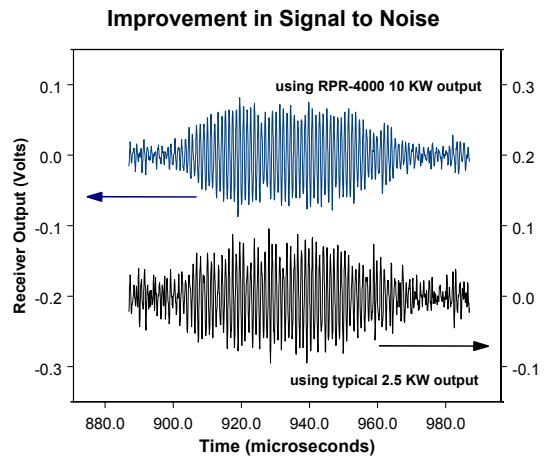

Figure 10

*Comparison between two transmitted power
levels on signal-to-noise ratio.*

Every effort was made to anticipate the questions of potential users in this descriptive sheet. However, it is recognized that it is not possible to predict all the possible uses of the RITEC RPR-4000 system or even the concerns of engineers wishing to use it for standard applications. If there are any questions about the applicability of this instrumentation for a specific or general requirement, please contact any of RITEC's engineers (Bruce Chick, Gary Petersen, Mark McKenna, Michael Ragosta or Arthur Bernier) and they will endeavor to be of assistance.

SPECIFICATIONS

The unit can be mounted in a standard 19-inch rack. The height is 7 inches (17.8 cm) (4U) while the depth is 17 inches (43.2 cm). Total weight is approximately 30 pounds (~13.6 KG). Universal line voltage requirements are from 85 to 240 Volts RMS at 50 to 60 Hertz. Total input power is approximately 300 Volt Amperes at maximum duty cycle and maximum power output.

PULSER

1. Sinusoidal Radio Frequency (RF) Tone Burst with two standard frequency ranges of either 50 kHz to 2 MHz or 250 kHz to 5 MHz, at specified powers.
2. Power Output: Low frequency unit; 8 kW up to 500 kHz decreasing slowly to 500 W at 5 MHz. High frequency unit; 8 kW up to 2 MHz, 5 kW at 3 MHz, 1.25 kW at 8 MHz and decreasing slowly to 100 W at 20 MHz. The saturated power output in the primary frequency ranges is ~10 kW.
3. Pulse Width: controllable in increments of time or in cycles of RF.
4. Maximum Pulse Width: limited by hardware to a maximum of 200 microseconds; limited by software not to exceed maximum duty cycle at each setting for the repetition rate.
5. Maximum Duty Cycle: 1%, limited by over current and over temperature settings.
6. Level Control: Greater than 30 dB with 12 bit A/D control.
7. Peak detector presentation on front panel display shows approximate peak positive output voltage of the gated amplifier.
8. Two external inputs are provided so that an externally produced RF source, such as a chirp signal, and corresponding gate can be introduced into the pulser.
9. A diplexer (transmit/receive switch) is located at the pulser output for pulse/echo operation. The insertion loss for returned signals is approximately 3 dB.
10. Three different protection circuits are provided: over current, over voltage and over temperature.

RECEIVER

1. Total Gain: 20 dB to 100 dB
2. Gain Control: 80 dB in 0.4 dB steps
3. Noise Figure: Approximately 6 dB at maximum gain.
4. Inputs: Two low noise inputs selectable from the front panel keypad or from the computer. A unique feature is the automatic diplexing setting where each input is selected on alternate triggers.
5. Four high pass filters: 0.05, 0.2, 0.4, and 0.8 MHz are standard in the low frequency unit: 0.2, 0.4, 0.8, and 22 MHz are standard in the high frequency unit.
6. Four low pass filters: 0.2, 0.8, 1.6 and 22 MHz are standard in the low frequency unit: 2.5, 5, 10, and 22 MHz are standard in the high frequency unit.
7. Maximum bandwidth: 50 kHz to 20 MHz
8. Input Impedance: Nominally 50 Ohms
9. Output Impedance: 50 Ohms
10. Linear Output Level: 1 Volts peak-to-peak into 50 Ohms; maximum output level 6 Volts peak-to-peak.
11. Minimum Input for Full Output: Approximately 20 microvolts peak-to-peak.
12. Two voltages of +12 V and -12V are available via a rear panel connector, along with ground, to power an external low noise pre-amplifier. The maximum current available is 100 milliamperes from each supply.

RITEC, Inc. • 60 Alhambra Rd., Suite 5 • Warwick, RI 02886

(401) 738-3660 • FAX (401) 738-3661

www.RitecInc.com

SYNCHRONIZATION

1. Triggered Internally, Externally or from the Computer.
2. Internal Range: 0.08 Hz to 10,000 Hz in 42 steps in a 1, 1.25, 1.5, 1.6, 2, 2.5, 4, 5, 8, 10 sequence.
3. Positive trigger output coherent with the RF burst always available.
4. 20 MHz clock output coherent with the RF burst always available.
5. External Trigger Input Connector on rear panel.
6. Can accept external gating signal and external RF signal (1 V peak-to-peak) from an arbitrary waveform generator.

SETUP PROGRAMS

Settings can be saved in one of 10 setting memories for easy recall. Settings files can also be downloaded from an external computer to one of the 10 memory locations.

DISPLAY

The Front Panel Operator's Console consists of a liquid crystal display and a 16 key keypad. The display is a 4 line by 20 character dot-matrix liquid crystal display (LCD) with LED backlighting. It will display alphanumeric characters in 5 x 8 dot character font. The viewing area dimensions are 76 x 26 mm.

KEYPAD

The keypad is a 4x 4 matrix membrane keypad with tactile feedback. The 16 keys are labeled as follows: 0 thru 9; Up, Down, Left, & Right arrows; Enter; Page. The keypad dimensions are: 5" x 7" (127 x 178 mm).

RITEC, Inc. • 60 Alhambra Rd., Suite 5 • Warwick, RI 02886

(401) 738-3660 • FAX (401) 738-3661

www.RitecInc.com

Page 10 of 10